

Var. 02

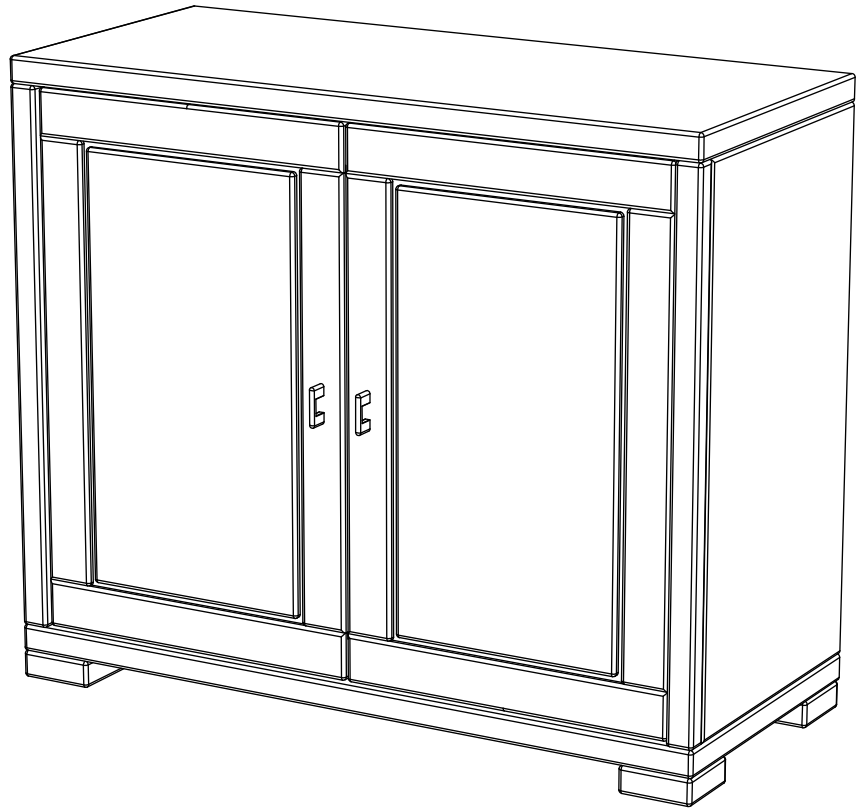

Var. 01

Assembled size / Maße aufgebaut :

Height / Höhe : 923 mm.

Width / Breite : 1090 mm.

Depth / Tiefe : 473 mm.

This unit can be assembled by two persons.

Aufbau mit zwei Personen.

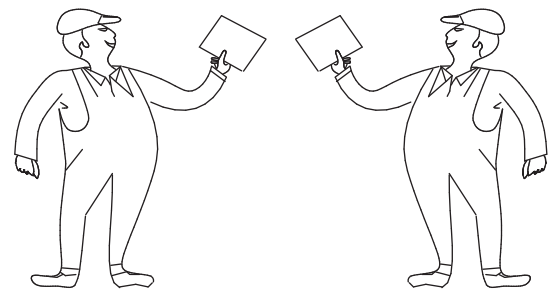

Herzlichen Glückwunsch
Sie haben ein Qualitätsprodukt gekauft.
Beachten Sie bitte:

Massiv-Holz ist ein organisches Material und passt sich den jeweiligen Umweltbedingungen an. Leichter Verzug, Haarrisse und Oberflächendetails sind daher kein Reklamationsgrund, sondern ein Qualitätsmerkmal des Materials.

**The necessary tools
(not included)**

**Die dazu benötigten Werkzeuge
(ausschliesslich)**

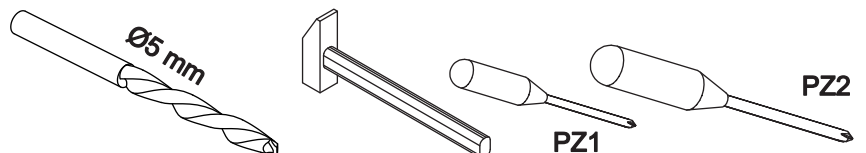

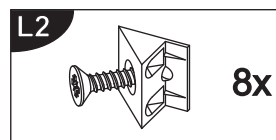
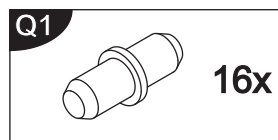
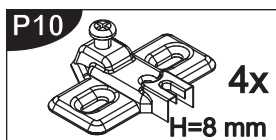
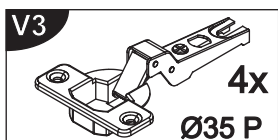
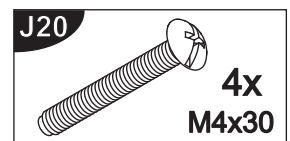
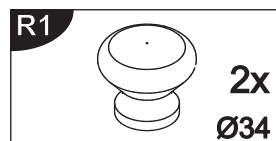
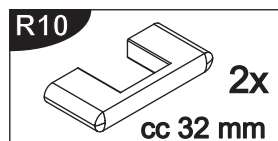
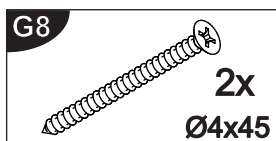
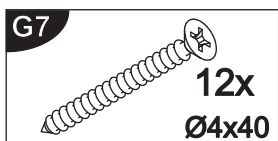
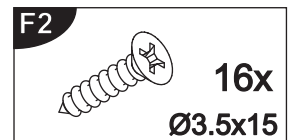
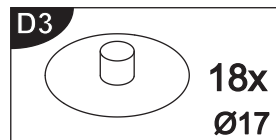
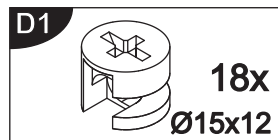
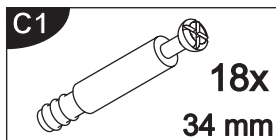
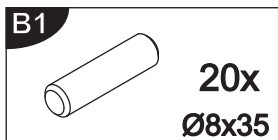
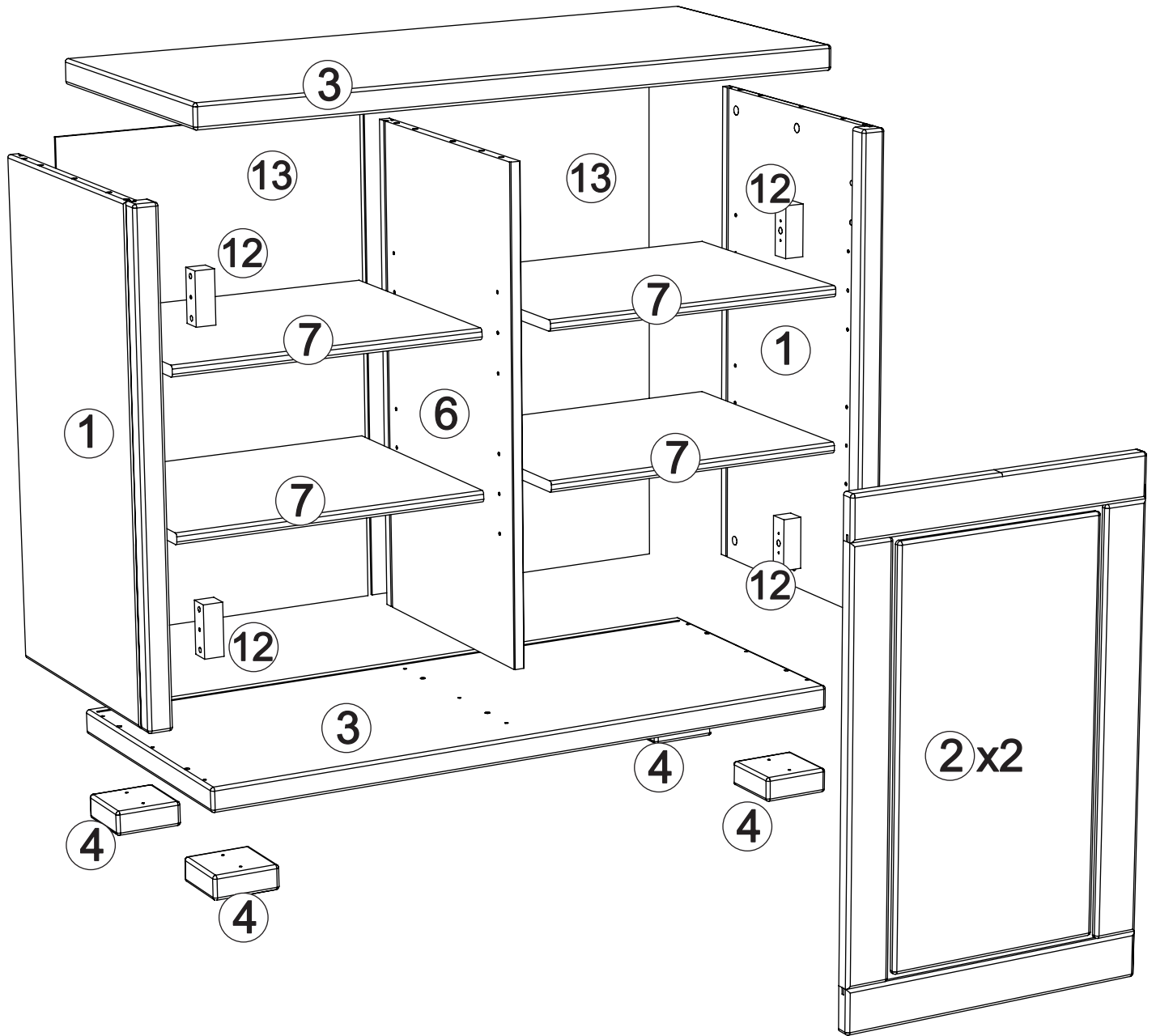

1 B1 x 12 D1 x 18

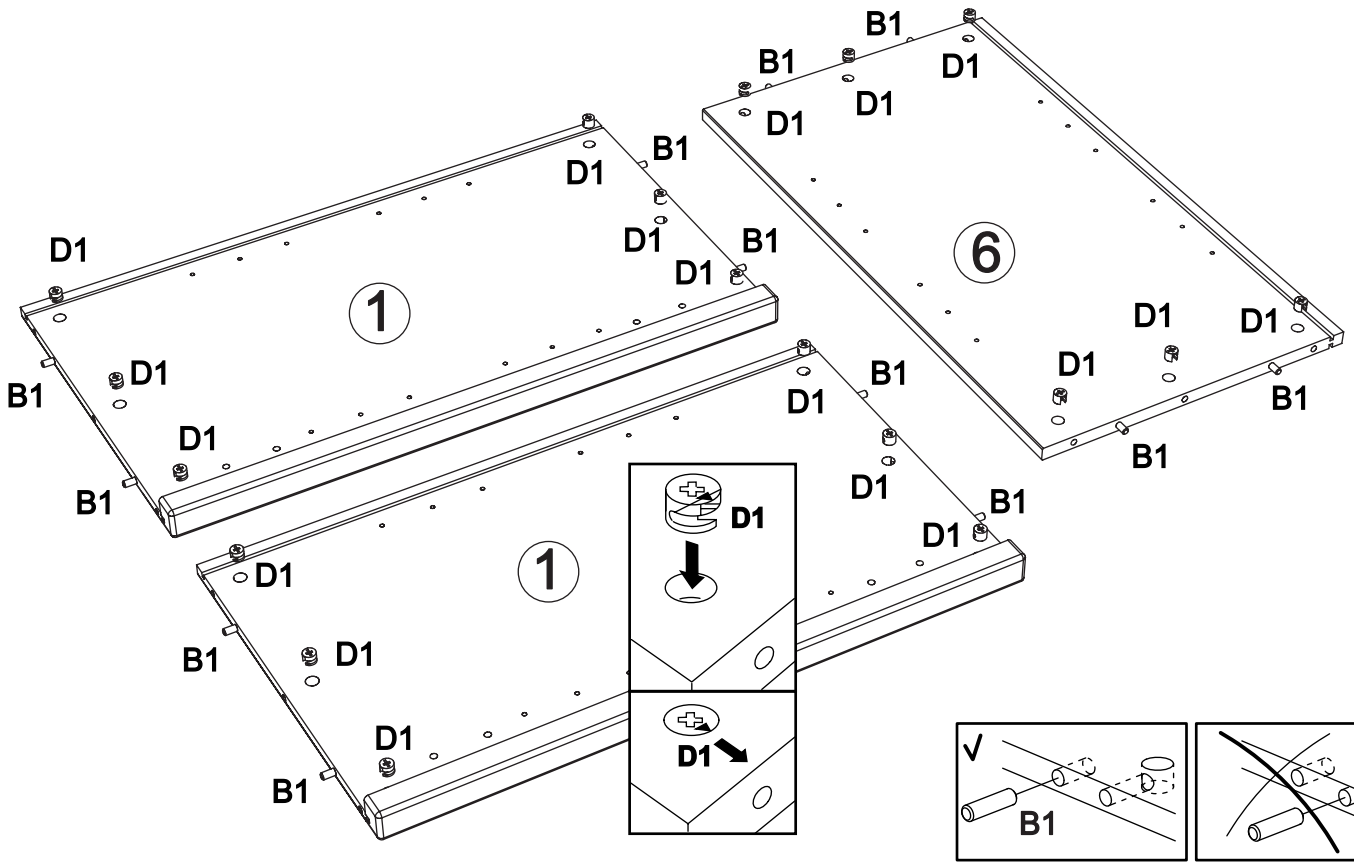

2 B1 x 8 G7 x 4

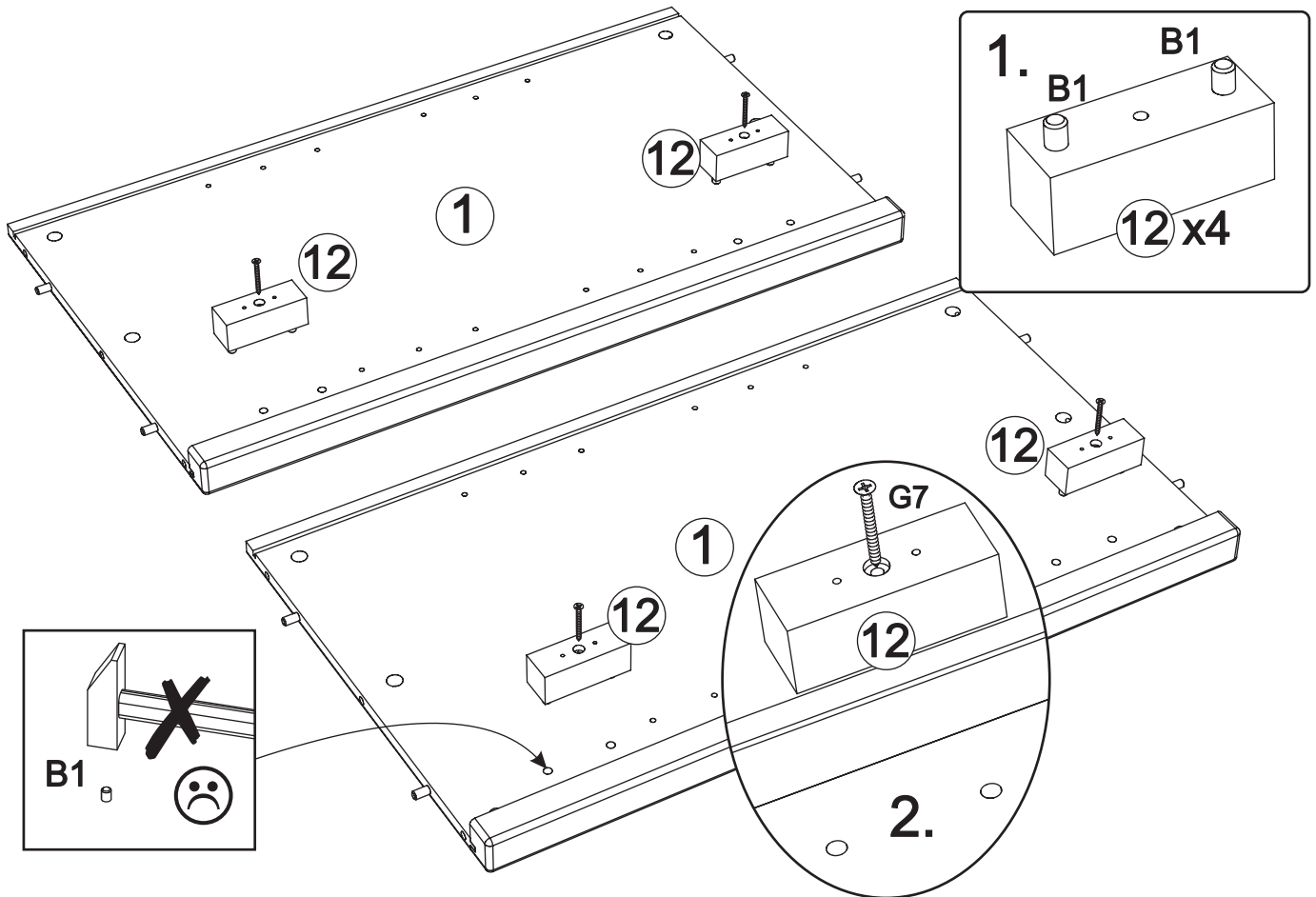

3

F2 x 8

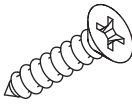

P10 x 4

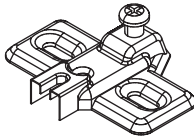

PZ2

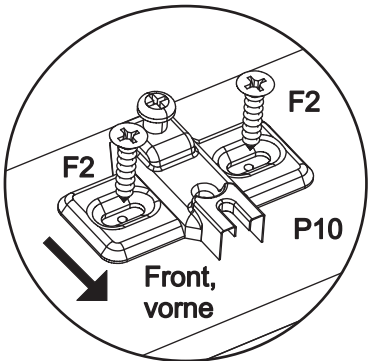
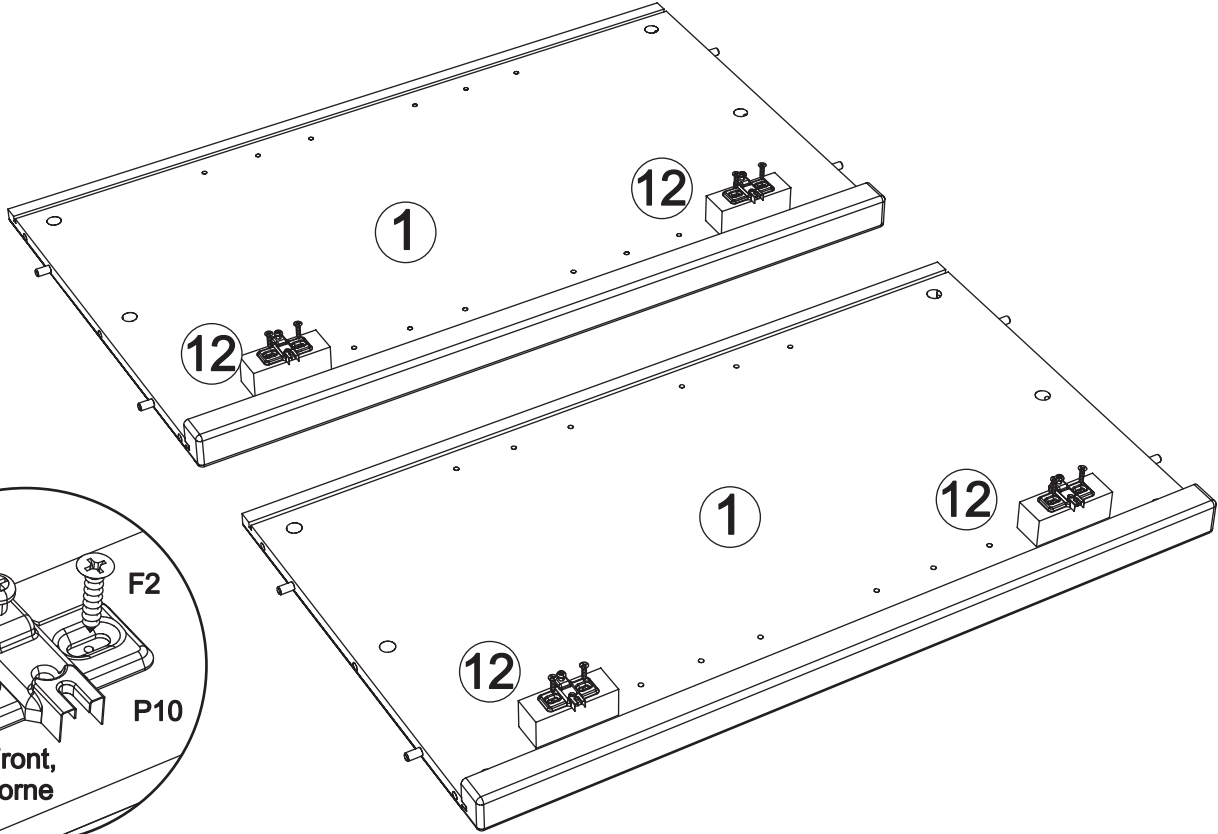

4

G7 x 8

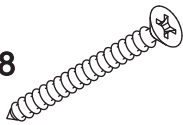

PZ2

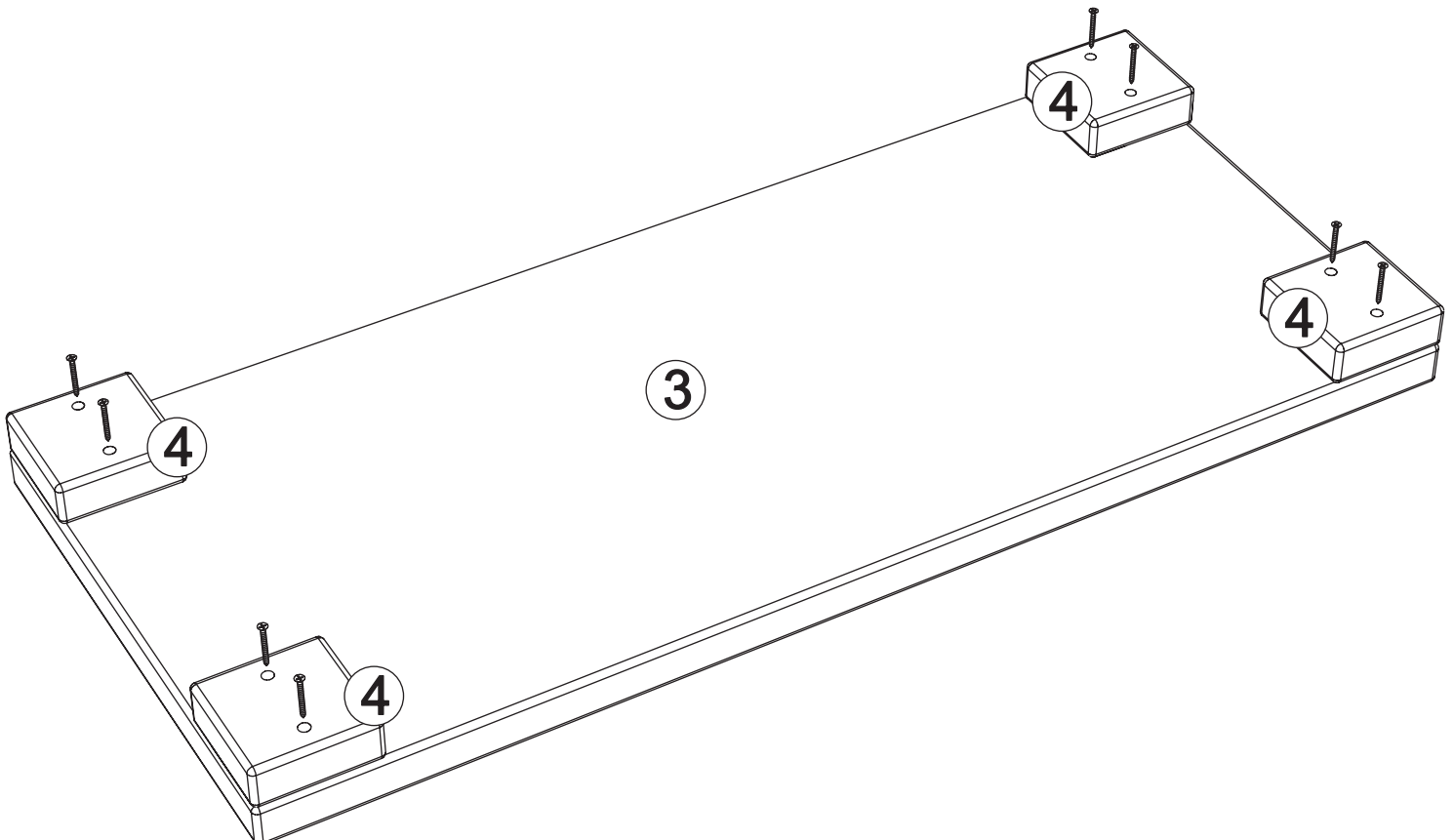

5

C1 x 18

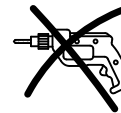
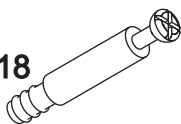

PZ2

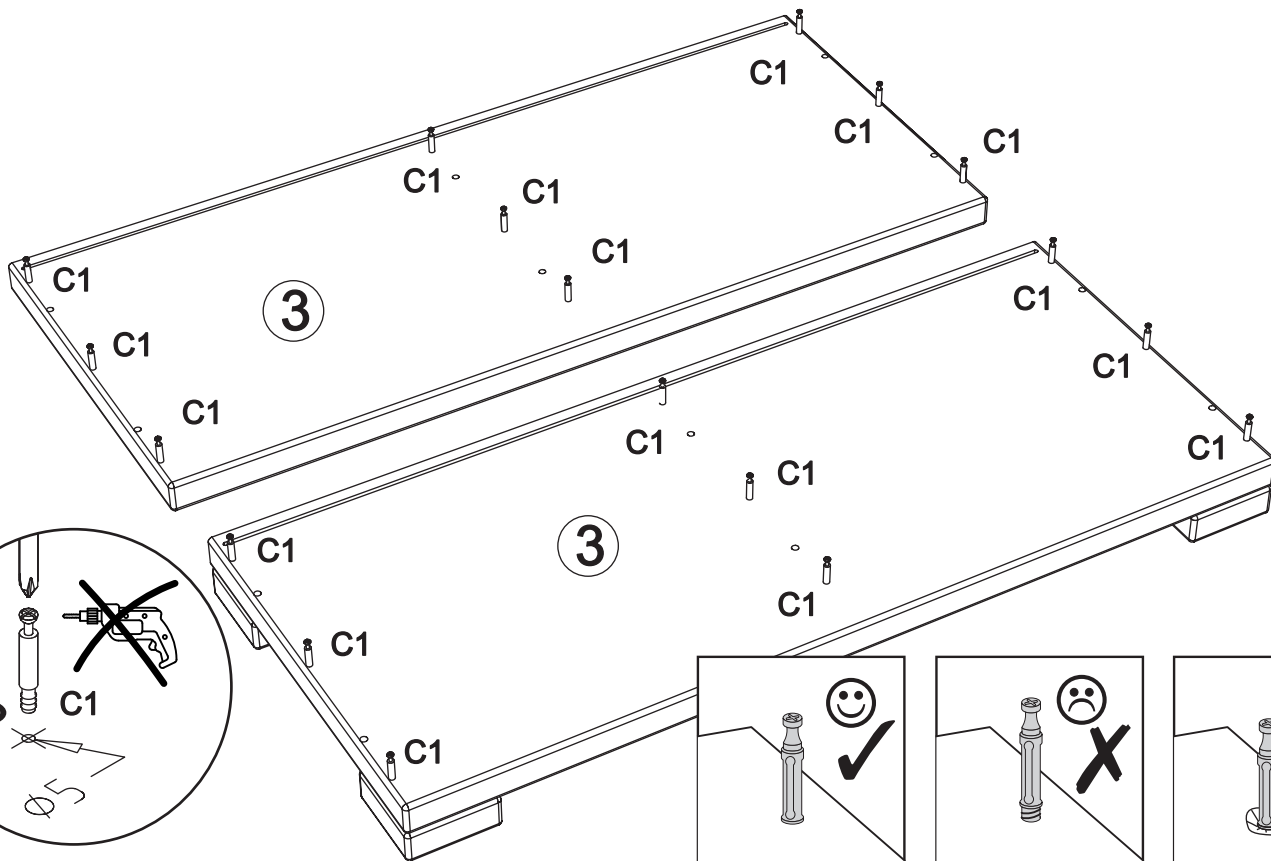

6

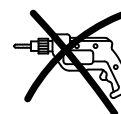

PZ2

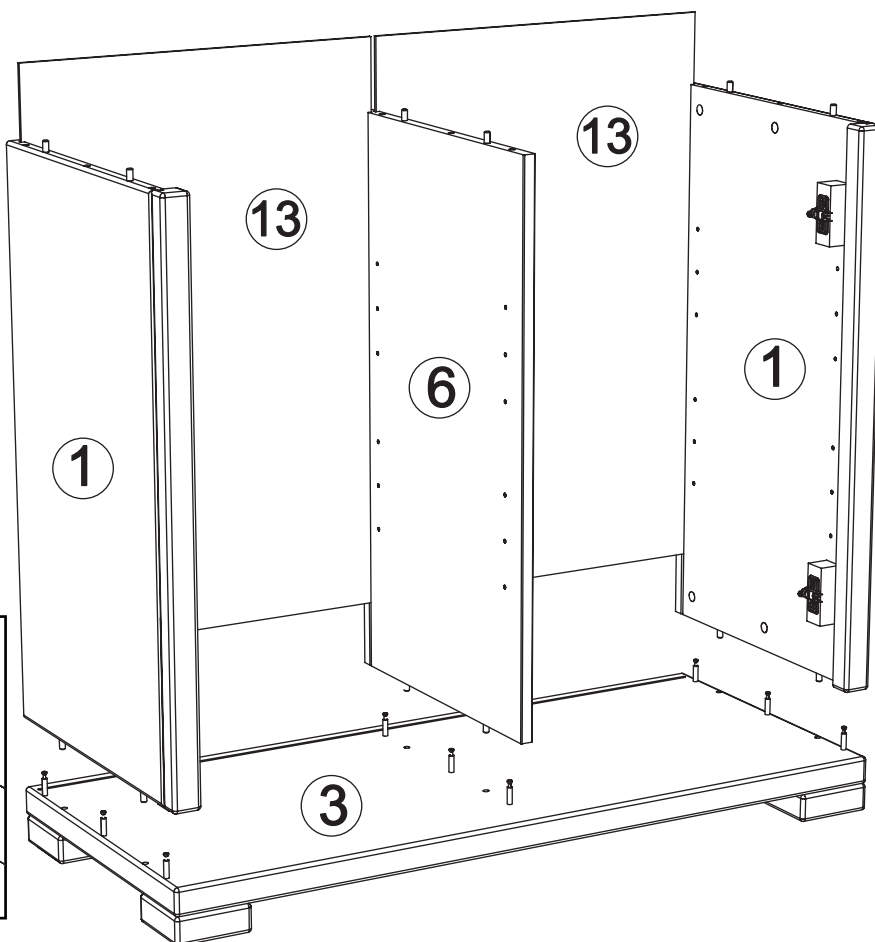

D1 x 9

7

D3 x 18

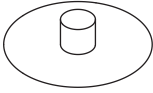

PZ2

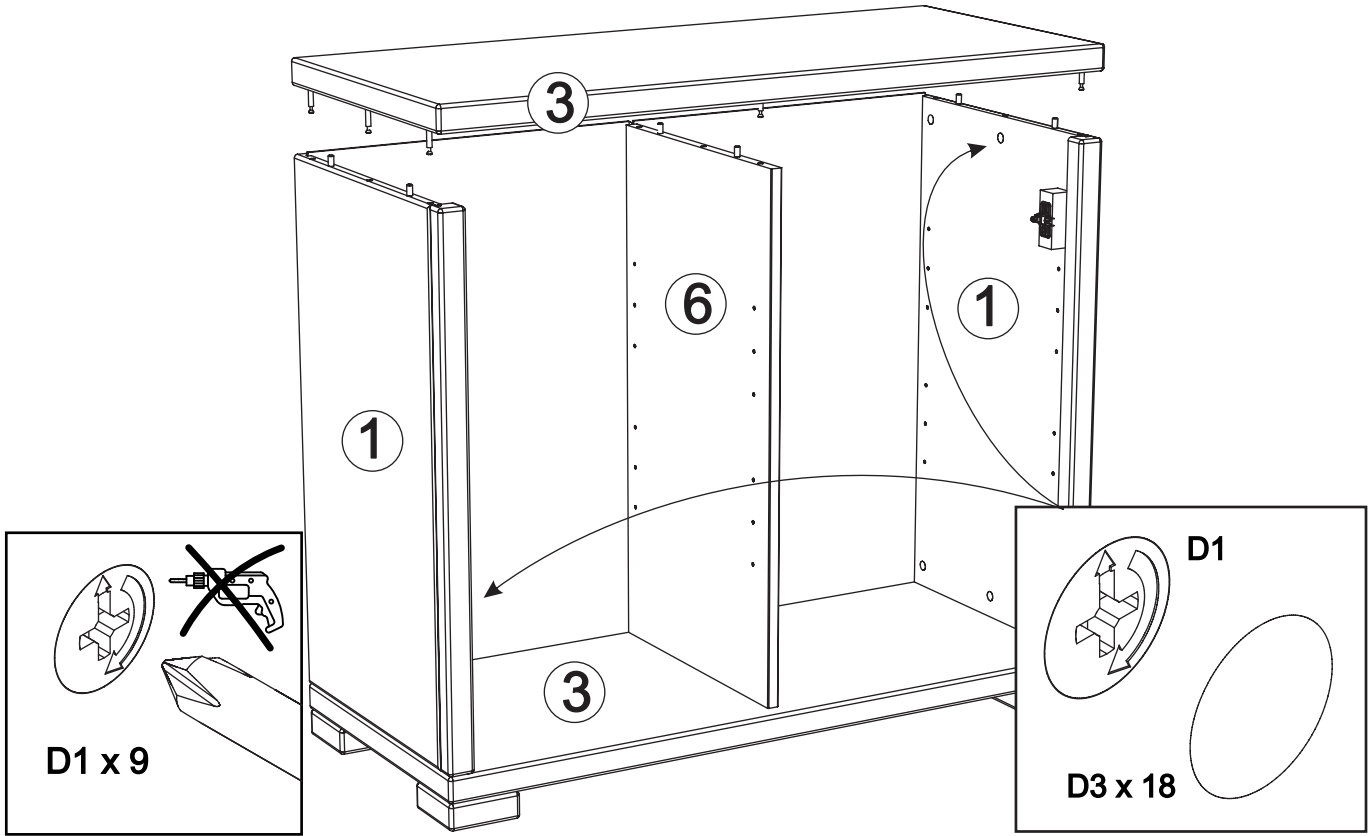

8

L2 x 8

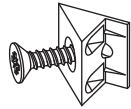

PZ2

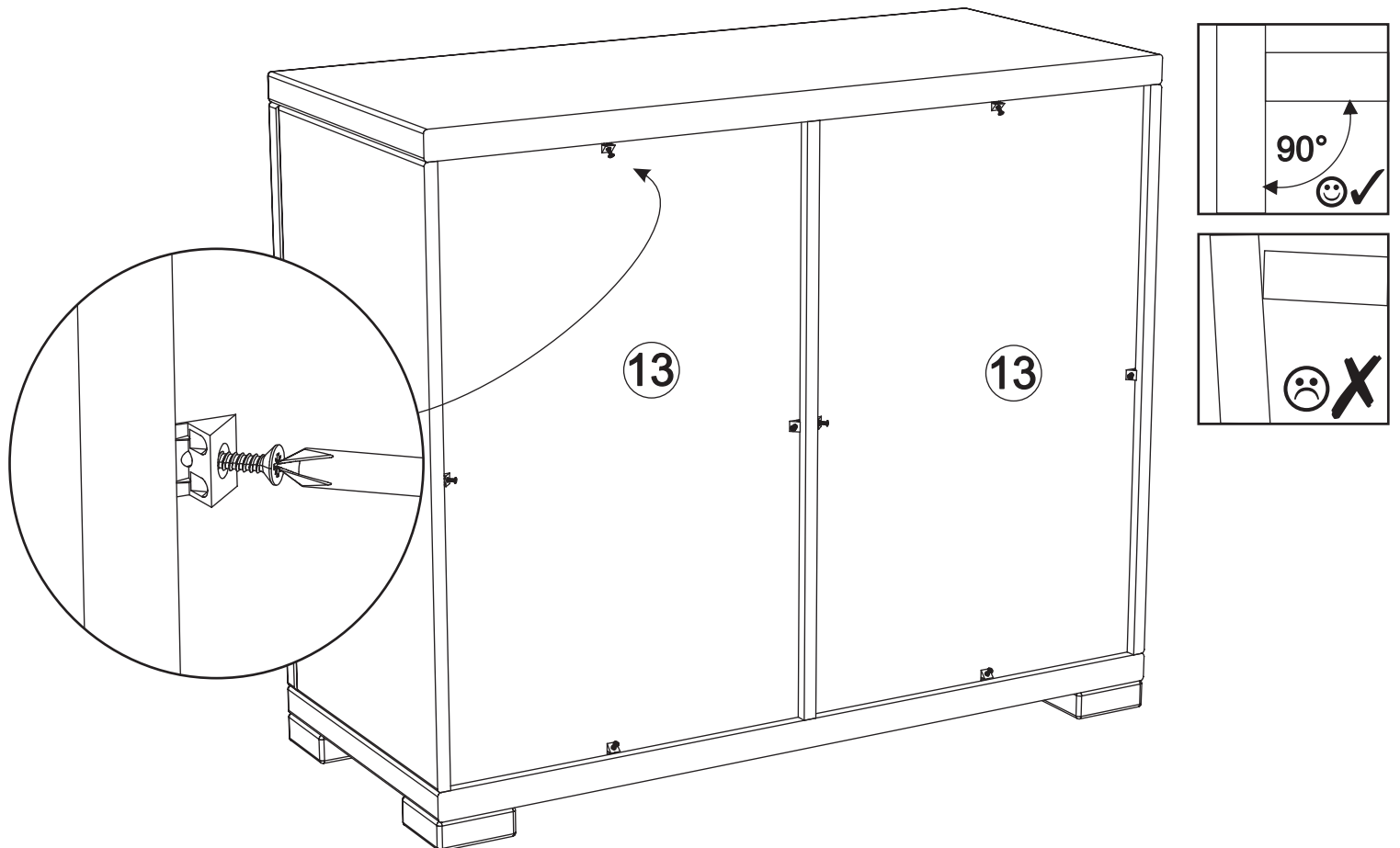

9 Var. 01

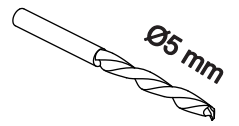

!!! ACHTUNG:
Bei der MONTAGE DER GRIFFE
unbedingt darauf achten, dass beim
Nachbohren oder durchstechen der
vorgebohrten Löcher von vorne
ein Holzstück oder ähnliches
gegen gehalten wird. Damit
ein ausspalten verhindert wird.
Aufpassen, dass die richtigen
Löcher verwendet werden.

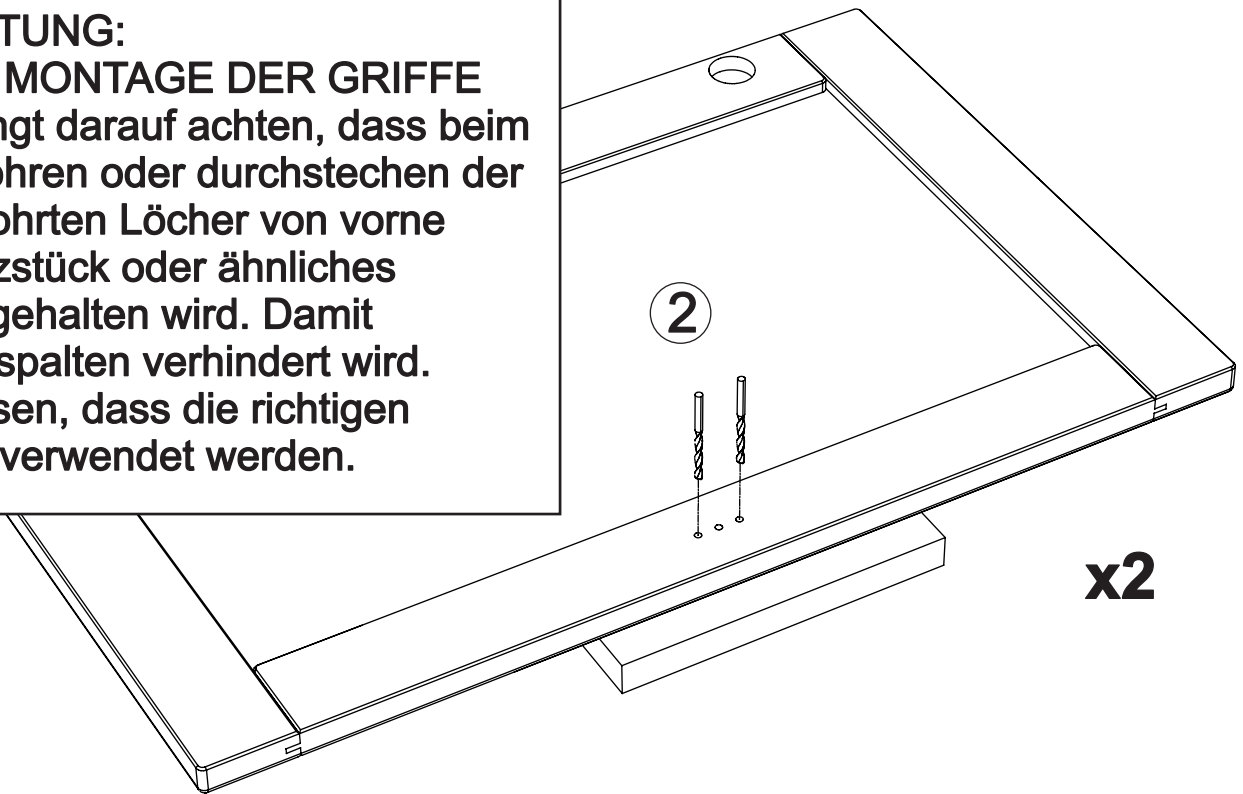

9 Var. 02

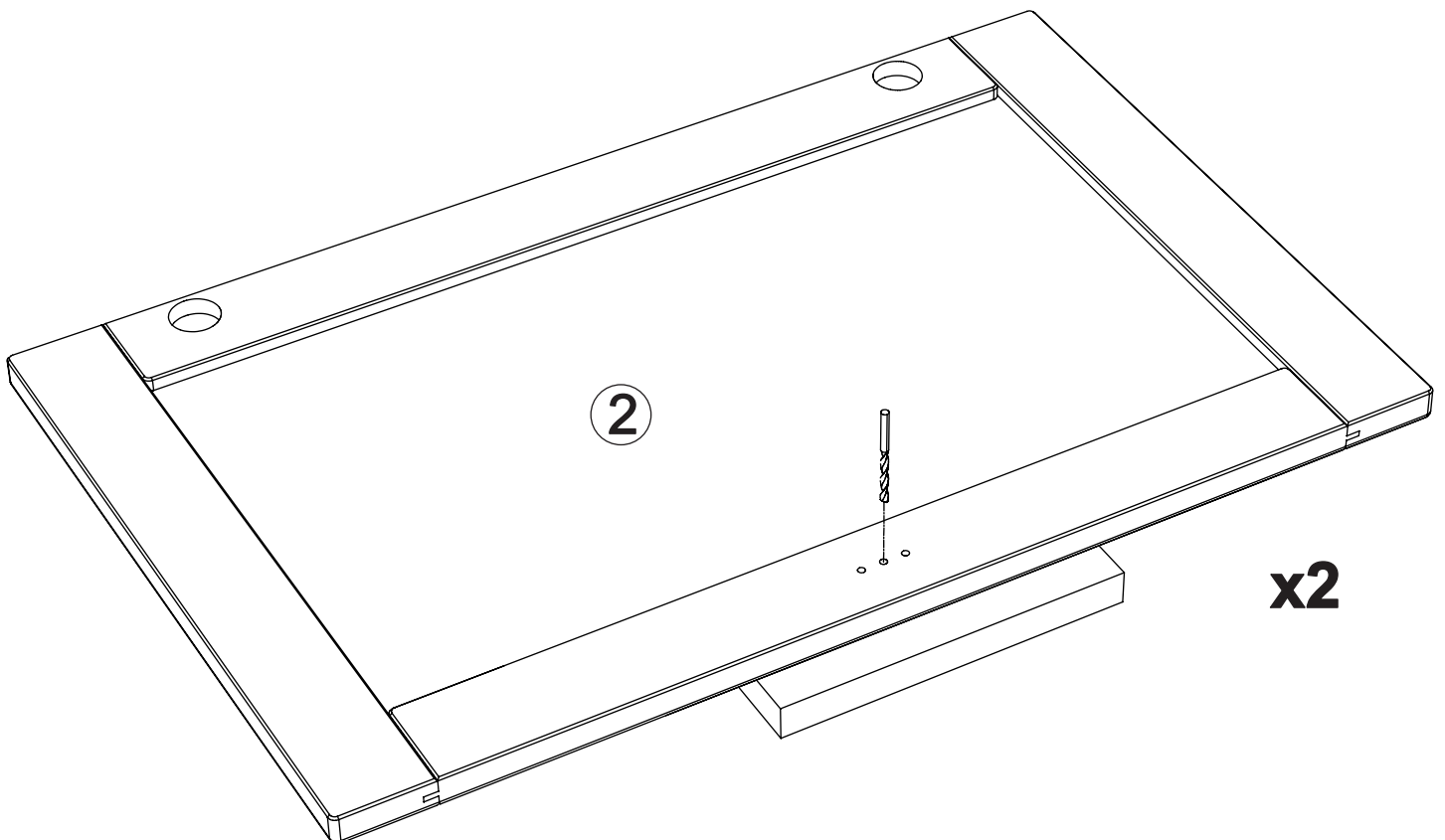
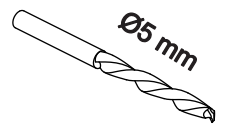

10

F2 x 8

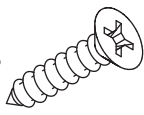

V3 x 4

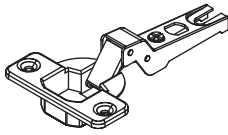

PZ2

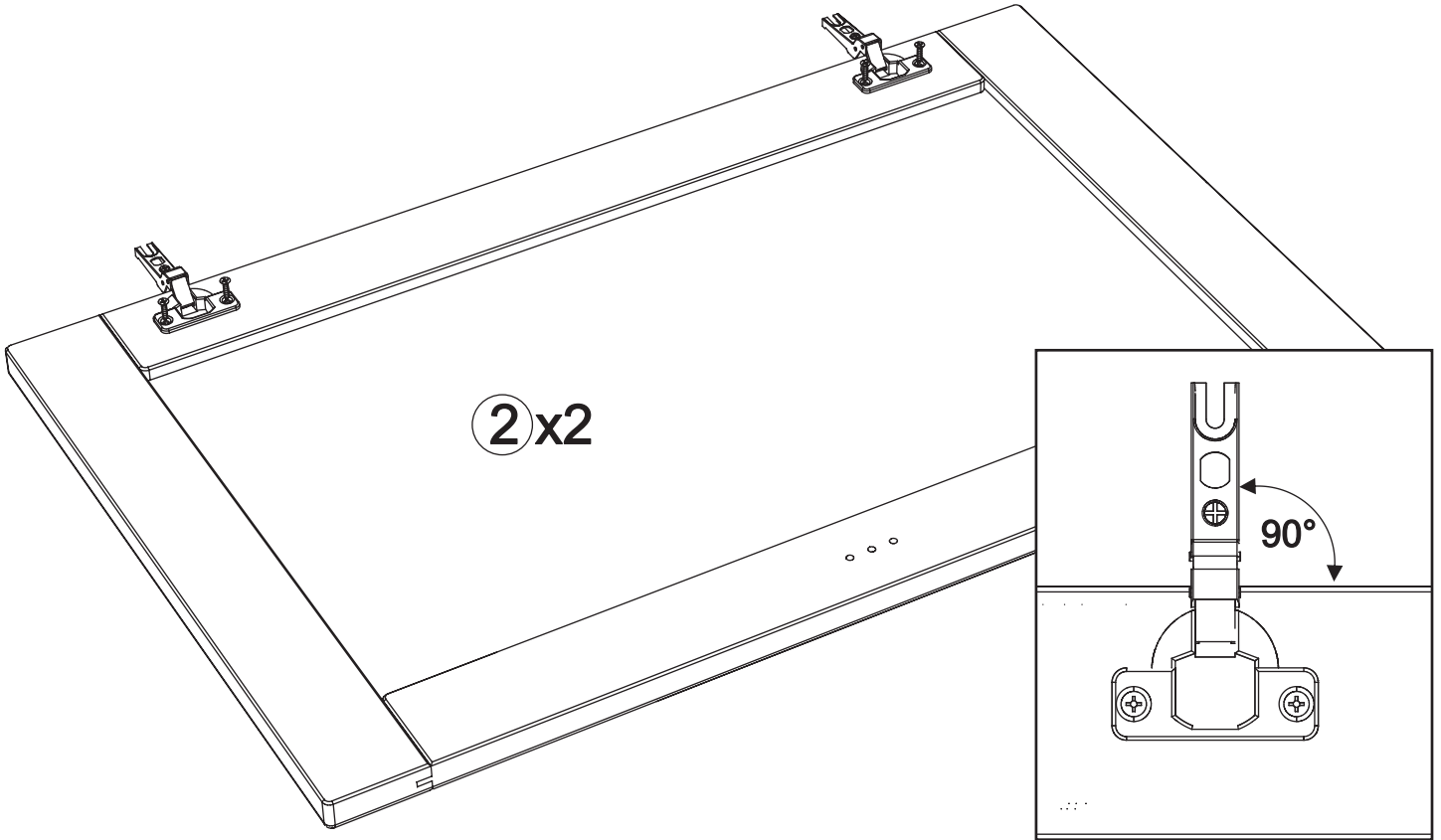

11

Q1 x 16

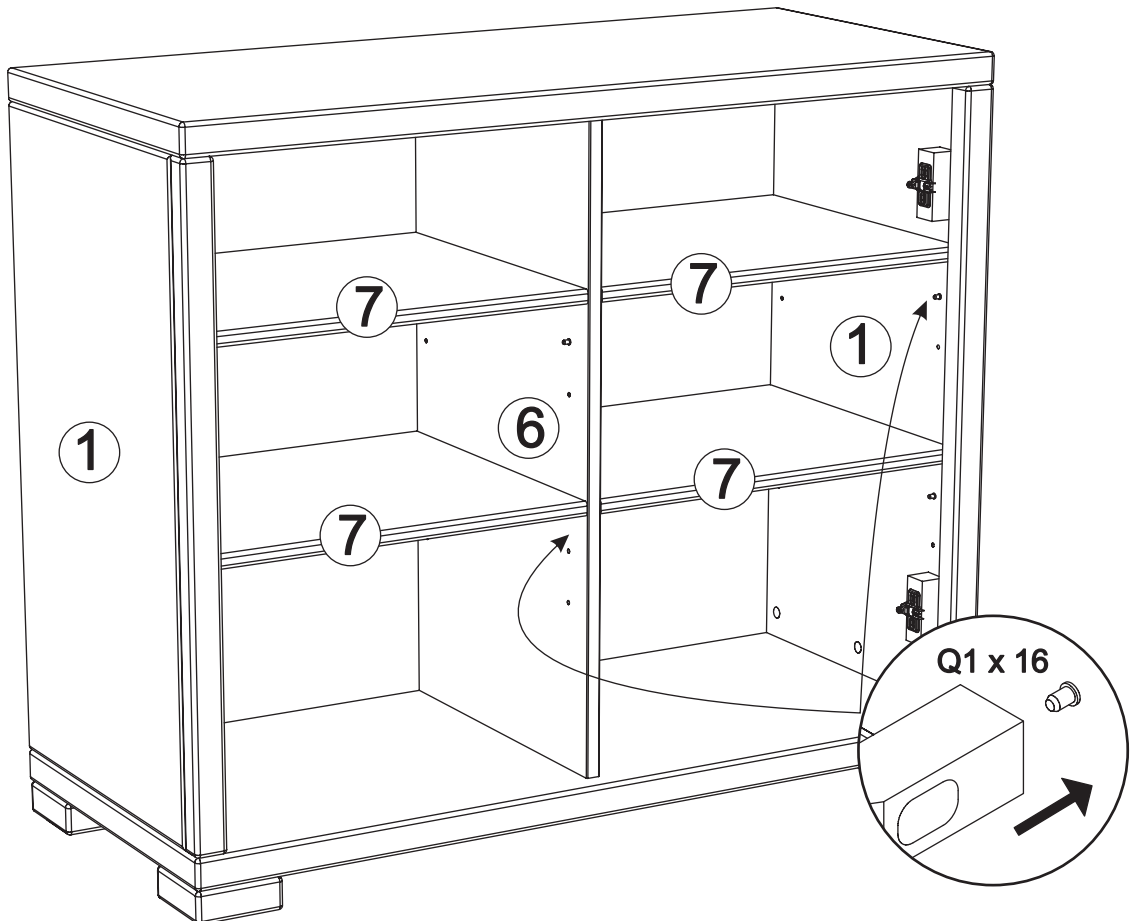
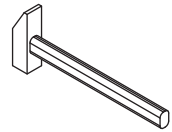
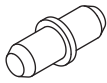

12

Var. 01

J20 x 4

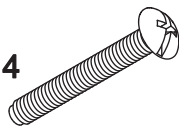

R10 x 2

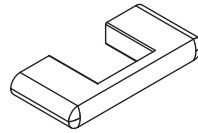

PZ2

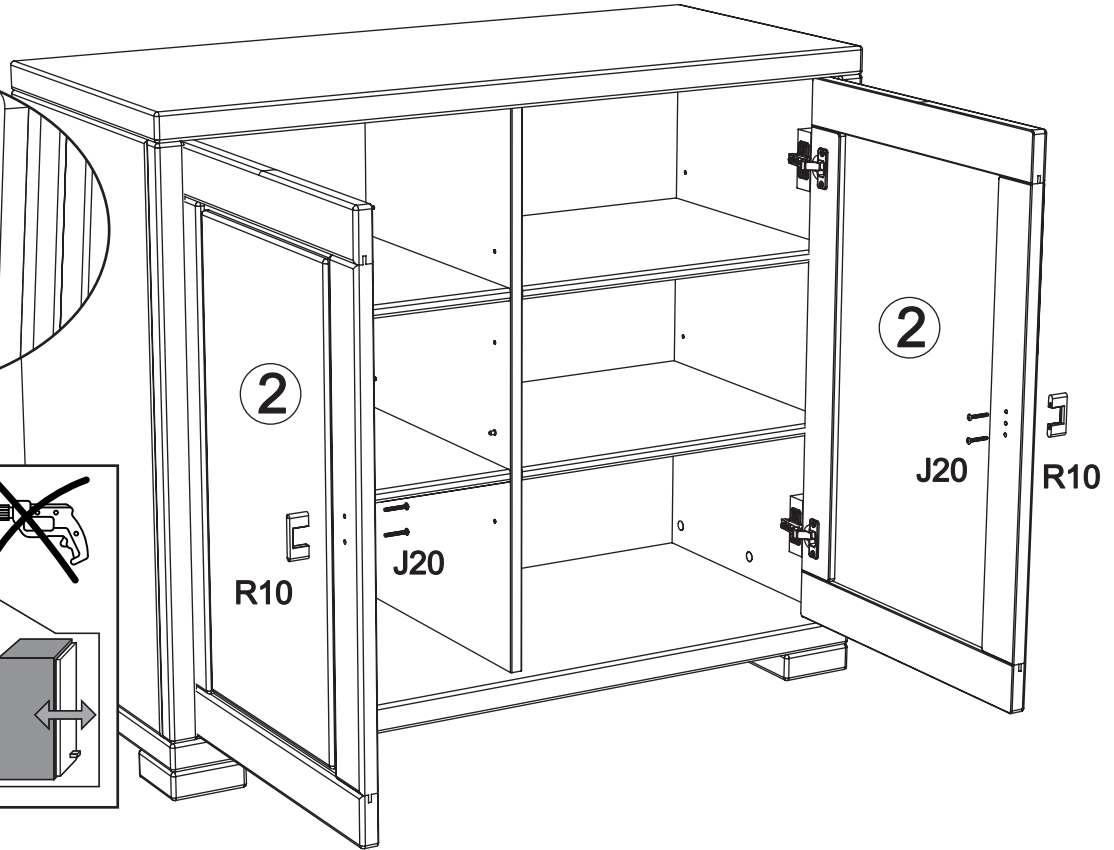
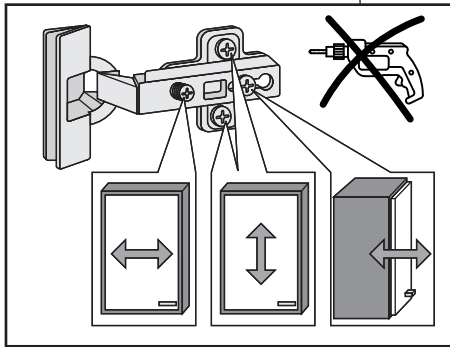
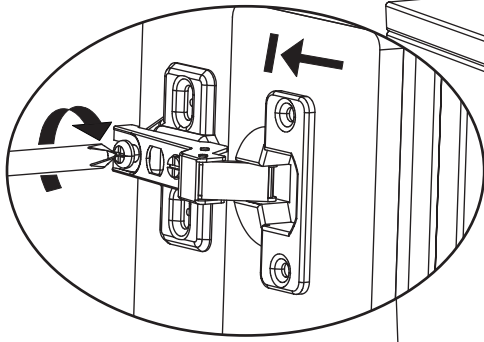

12

Var. 02

R1 x 2

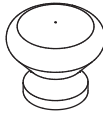

G8 x 2

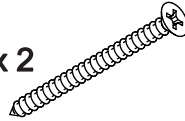

PZ2

